

Head Office:

F/S14, Bayint Naung Road,
Shwe Sabi Yeik Mon,
Kamayut Township,
Yangon, Myanmar.
Hotline : 09420077507,09780002400

Factory:

Blk-94(A+B), 42nd Quarter,
Kha Yae Pin Street,
Industrial Estate,
Shwe Pyi Tha Township,
Yangon, Myanmar

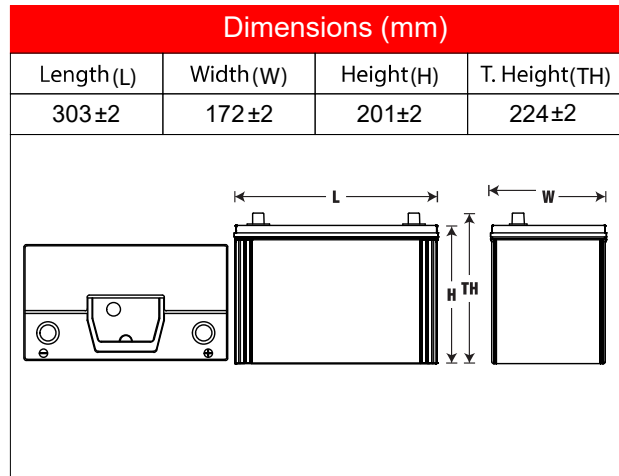

Physical Specification

Nominal Voltage	12 V	
Nominal Capacity (20 Hour Rate)	80 Ah	
Dimension	Length	303 ±2 mm
	Width	172 ±2 mm
	Container Height	201 ±2 mm
	Total Height	224 ±2 mm
Weight (approximate)	21.5 Kg	
Terminal Design	T2	
Cell Layout	0/1	
Hold Down	Not Available	
Case	PP - Black	
Cover	PP - Black	
Handle	PP - Red	

Electrical Specification

Rated Capacity (20 Hour Rate @ 4.00 A)	80 Ah
Reserve Capacity	125 Min.
Cold Cranking Performance @ 0°F (-18°C)	650 A

